

CERTIFICATE OF SURVEY

PART OF THE SOUTHWEST QUARTER OF THE SOUTHWEST QUARTER,
SECTION 3, TOWNSHIP 136 NORTH, RANGE 30 WEST,
CASS COUNTY, MINNESOTA

PROPOSED BOUNDARY DESCRIPTIONS:

TRACT A (Thrun to Nelson)

That part of the Southeast Quarter of the Southwest Quarter of the Southwest Quarter, Section 3, Township 136 North, Range 30 West, Cass County, Minnesota, lying west of the east 592.00 feet thereof.

Subject to easements, restrictions and reservations of record.

TRACT B (Nelson to Thrun)

The south 84.50 feet of the east 592.00 feet of the Northeast Quarter of the Southwest Quarter of the Southwest Quarter, Section 3, Township 136 North, Range 30 West, Cass County, Minnesota.







Subject to easements, restrictions and reservations of record.

Owner: David D. & Colleen R. Nelson
2817 N 2nd St.
Minneapolis, MN 55411
PID#: 23-003-3300

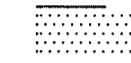
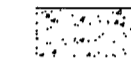
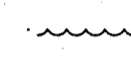
Owner: David D. & Colleen R. Nelson
2817 N 2nd St.
Minneapolis, MN 55411
PID#: 23-003-3301

Owner: Scott M & Jessica A. Thrun
3208 52nd St SW
Pequot Lakes, MN 56472
PID#: 23-003-3302

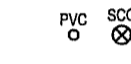
LEGEND

-  DENOTES EDGE OF EXISTING GRAVEL
-  DENOTES EDGE OF EXISTING CONCRETE
-  DENOTES EDGE OF TREELINE
-  DENOTES EXISTING ELECTRIC OUTLET
-  DENOTES EXISTING WELL
-  DENOTES EXISTING HOSE BIB
-  DENOTES EXISTING SEPTIC VENT, SEPTIC CLEANOUT, & SEPTIC TANK LID
-  DENOTES MONUMENT FOUND
-  DENOTES IRON MONUMENT SET MARKED BY LICENSE No. 44881

ORIENTATION OF THIS BEARING SYSTEM IS BASED ON THE CASS COUNTY COORDINATE SYSTEM.

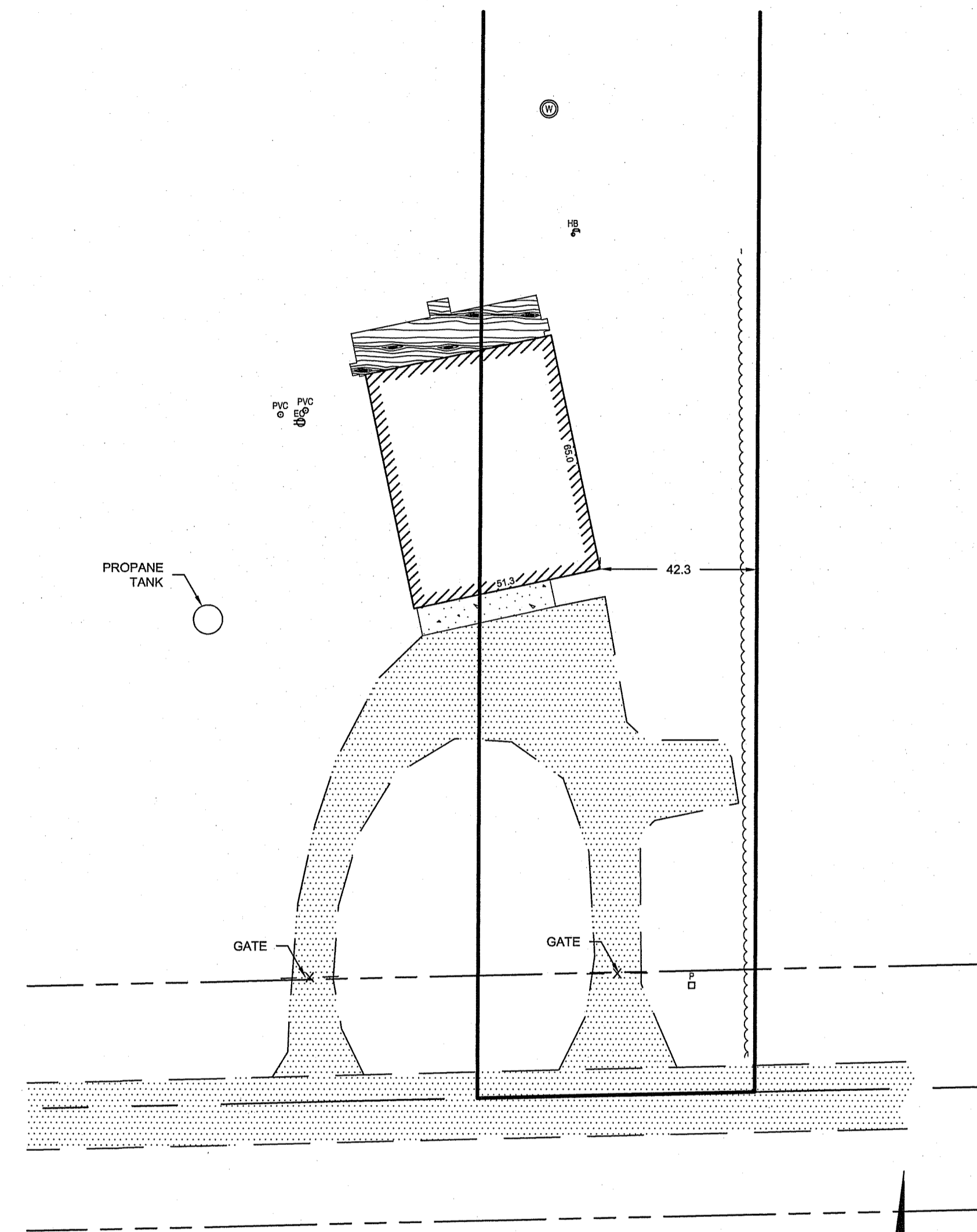

DETAIL

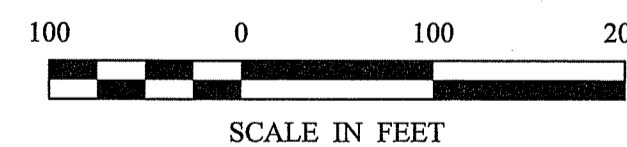
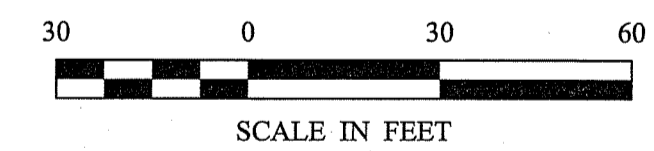

NOTES:

1. Zoning for subject tract = "Agricultural/Forestry".
2. Parcel ID of subject parcels: 23-003-3300, 23-003-3301 & 23-003-3302.
3. The property address of subject parcel: 3208 52nd St. SW.
4. Tract A is to be combined with parcel to the west PID# 23-003-3301 and Tract B is to be combined with parcel to the south PID# 23-003-3302.

	
I HEREBY CERTIFY THAT THIS SURVEY PLAN, SPECIFICATION OR REPORT WAS PREPARED BY ME OR UNDER MY DIRECT SUPERVISION AND THAT I AM A DULY LICENSED PROFESSIONAL ENGINEER OR LAND SURVEYOR UNDER THE LAWS OF THE STATE OF MINNESOTA. David D. Nelson Cass County, Minnesota License No. 44881	
PROJECT MANAGER: CMH CHECKED BY: CMH DRAWN BY: RJF	PROJECT NO.: 18198 FILE NAME: C18198.dwg FIELD BOOK: PG. NA BOOK NA: PG. NA
DATE: 7-16-2018 SCALE: AS NOTED HORZ.: AS NOTED VERT.: NONE	REVISIONS: DESCRIPTION: Added digitized building and driveway DATE: 7-16-2018 BY: RJF
CERTIFICATE OF SURVEY David Nelson 2817 N 2nd Street Minneapolis, MN 56472	
1 OF 1	