

# CERTIFICATE OF SURVEY

LOTS 1 & 2, BLOCK ONE, HILLAWAY,  
SECTION 11, TOWNSHIP 140 NORTH, RANGE 31 WEST,  
CASS COUNTY, MINNESOTA

## Ten Mile Lake

General Development Classification

LAKE ELEVATION = 1379.80 top of ice (02-16-2017)

ORDINARY HIGH WATER ELEVATION = 1379.9  
HIGHEST RECORDED ELEVATION = 1380.23 (06-14-2001)  
LOWEST RECORDED ELEVATION = 1377.49 (11-23-1976)

BASED ON NGVD29

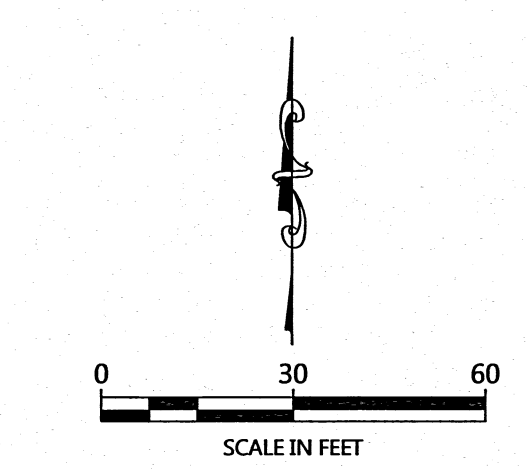

ORIENTATION OF THIS BEARING SYSTEM IS BASED ON THE MINNESOTA COUNTY COORDINATE SYSTEM, (CASS COUNTY NORTH ZONE).

### LEGEND

- DENOTES IRON MONUMENT SET & MARKED BY LICENSE NO. 21367
- DENOTES MONUMENT FOUND
- × DENOTES CALCULATED POSITION
- ⊕ DENOTES BENCHMARK: NAIL SET IN WESTERLY SIDE OF A 14" RED PINE ELEV. = 1391.25 NGVD29
- ⊙ DENOTES EXISTING WELL
- ⊕ DENOTES EXISTING SEPTIC CLEANOUT
- ⊕ DENOTES EXISTING PHONE PEDESTAL
- ⊕ DENOTES EXISTING ELECTRIC METER
- ⊕ DENOTES EXISTING SEPTIC LIFT STATION
- 1208— DENOTES EXISTING INTERMEDIATE CONTOURS
- 1210— DENOTES EXISTING INDEX CONTOURS
- × 1234.5 DENOTES SPOT ELEVATION (EXISTING GRADE)

### NOTES:

1. Zoning for subject tract = Shoreland Residential.
2. Parcel ID for subject tract = 16-391-0110 & 16-391-0120.
3. No wetland information has been surveyed or shown on this certificate. The National Wetland Inventory mappings do not indicate any wetlands on the subject property. No field verification has been done at this time.
4. All lines marked with flagging are only an approximation of the true boundary lines and are not to be used as an exact boundary location. Flagged lines should not be used for the establishment of improvements. To mark true boundary lines, additional monumentation would be required.
5. Northern Engineering and Consulting, Inc. was not given nor has conducted a current title search for the subject property. Therefore the information contained in a title search may or may not be accurately shown on this certificate.

NO.	DATE	DESCRIPTION

I HEREBY CERTIFY THAT THIS SURVEY, PLAN OR REPORT WAS PREPARED BY ME OR UNDER MY DIRECT SUPERVISION AND THAT I AM A LICENSED SURVEYOR UNDER THE LAWS OF THE STATE OF MINNESOTA.

*Terry L. Freeman*  
TERRY L. FREEMAN  
4/6/17  
LIC. NO. 21367



CERTIFICATE OF SURVEY  
Mark Stonacek  
4350 Cooldidge Ave  
St. Louis Park, MN 55424

JOB NO. 17-026  
DATE: 04-06-2017  
SHEET NO.  
1 OF 1